

# Technical Service Bulletin

## Replacing End Units on Eliminator Torsion axles.

The purpose of this dealer bulletin is the proper way to replace a spindle/hub assembly from an Eliminator torsion axle. In many cases, repairs created by axle damage or warranty repair for leaking seals can be accomplished much easier and faster by replacing the entire assembly rather than replacing a seal or hub.

### 1. Remove tire/rim for hub

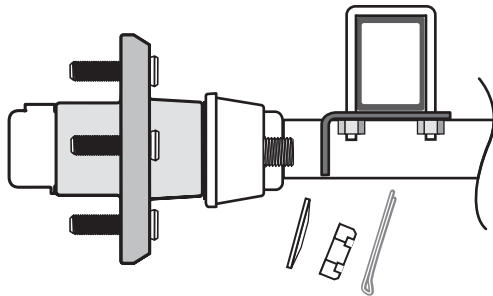

2 & 3, Remove cotter pin, castle nut and washer

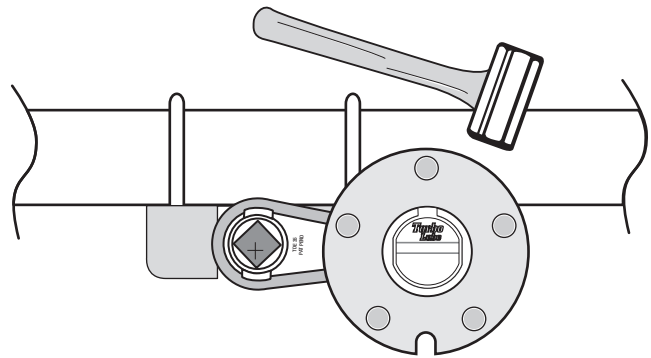

4. Loosen torsion arm by tapping the hub with a rubber hammer

1. Remove tire/rim from the hub. Place all hardware removed onto a clean area for reuse.
2. Using a pair of pliers, remove the SS cotter pin from the rear of the spindle, on the back side of the torsion arm.
3. Remove the castle nut and washer from the spindle.
4. The hub/spindle assembly can be loosened from the torsion arm by using a malleable or hard rubber hammer by tapping around the edge of the hub. If the torsion arm is exposed on the backside, you can place the castle nut back on the spindle so that it is even with the end of the spindle, and then hitting the rear of the spindle to force the spindle loose.
5. Remove the hub/spindle assemble.
6. Coat the conical portion of the spindle with an "anti-seize" compound before inserting into the torsion arm. Place the washer and castle nut on the spindle. Tighten castle nut to 100 ft. lbs. Insert SS cotter pin and bend in place.
7. Replace tire/wheel assembly and tighten lug nuts to manufacturers specifications.

