



***Vortex Lubrication
System Owners
Manual***

Vortex Wheel Hub/Spindle Operating Instructions

Simple is best when it comes to Wheel bearing lubrication. Tie Down has adapted the best features of grease and oil lubrication to develop the Vortex hub. The Vortex hub bearing lubrication system provides long term continuous bearing lubrication and ease of service or inspection.

Your trailer is equipped with Vortex hubs/spindles from Tie Down Engineering. The hubs are pre-greased and assembled at the factory and should not require any additional adjustments, The Vortex hub uses tapered roller bearings adjusted to a maximum .006 end play. The twelve sided castle nut easily maintains this maximum .006 end play. The configuration requires a minimal amount of end-play that is factored in at the time of assembly.

Vortex Features:

- Stainless steel wear sleeve on factory assembled spindle/hub units
- Vortex internal through the spindle lubrication system
- Super strong threaded removable grease cap
- Premium grade Lucas Oil Marine grease (100,000 miles)

What makes the Vortex the Best

The rear seal rides on a stainless steel wear sleeve. This provides longer life for the seal as the surface does not corrode. Corroded or rusted seal surfaces act like sandpaper on the seal causing premature failure.

Vortex lubrication makes changing or adding grease easy with no need to remove the hub. The threaded grease cap is easy to remove and replace. No more knocking the cap off with a hammer. Lucas Oil Marine grease is a premium lithium based complex fortified with rust and oxidation inhibitors, high pressure additives and provides a high degree of moisture resistance and washout properties.

These features allow Tie Down Engineering to offer a 6 year, 100,000 mile limited warranty. See separate warranty sheet for details.

The Vortex hub/spindle is designed to be a no maintenance hub for 6 years. If you should need to add grease or remove the hubs for any reason, follow the instructions listed in this owner's manual.

TO MAINTAIN THE FACTORY WARRANTY, LUCAS OIL MARINE GREASE MUST BE USED WHEN ADDING OR REPLACING GREASE IN THE VORTEX HUB.

Adding or changing Lucas Oil Marine grease in your Vortex hub

Your Vortex hub/spindle is equipped with the Vortex Lubrication System. Should the hub/bearings require additional lubrication for any reason, the Vortex lubrication system allows you to do so without removing the hub or having to re-adjust the bearings. New Lucas Oil Marine grease is pumped into the zerc fitting at the end of the spindle, travels to the rear bearing where the new grease pushes out the old grease through the rear bearing, center of hub and through the front bearing.

1. Remove the Vortex grease cap, unscrewing in a counter clockwise rotation.
2. Use a standard grease gun loaded with Lucas Oil marine grease to pump grease into the zerc fitting located on the end of the spindle.
3. Pump the Lucas Oil Marine grease into the zerc fitting while slowly rotating the wheel. Grease will flow out of the hub around the front bearing.
4. When the grease appears to be the new clean grease, remove the grease gun.
5. Replace the Vortex grease cap. Turn in a clock-wise rotation until the O-ring on the cap is in contact with the hub surface. Turn an additional 1/4 turn to seal the Vortex cap to the hub. (This is similar to installing an oil filter in an automobile)

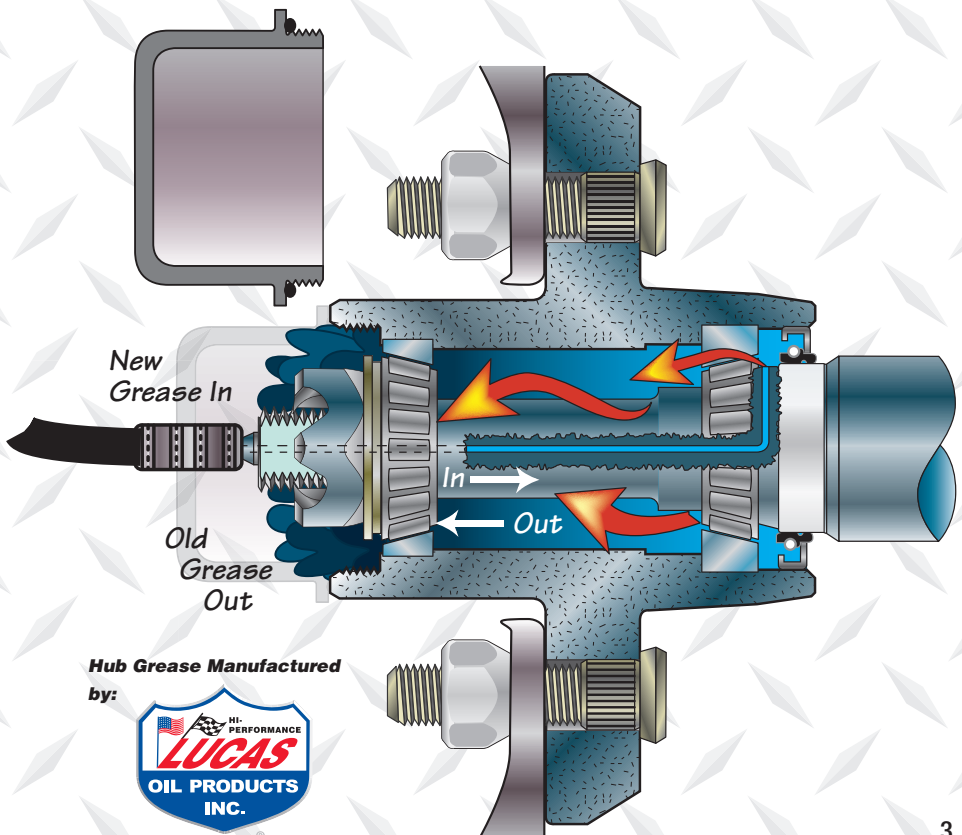

Removing/Remounting for the Vortex hub

Removing the Vortex hub for inspection or maintenance should be done in a safe location away from moving vehicles.

1. Elevate the trailer on level ground using the manufacturers instructions. Always use jack stands or other solid supports. Do not rely on a jack to support the trailer. Block wheels to keep the trailer from rolling.
2. Remove the tire/wheel assembly
3. Place a newspaper or cloth on the ground under the hub to keep any parts from falling onto a dirty surface.
4. Remove the Vortex grease cap by unscrewing in a counter clockwise rotation
5. Remove the cotter pin, castle nut (in a counter clockwise rotation) and washer
6. Remove the hub from the spindle. If you have disc brakes, you will need to remove the brake caliper to remove the rotor. Follow separate instructions for disc brake rotor removal
7. Be careful not to allow the bearings to fall out of the hub
8. Clean bearing and cup surfaces
9. To re-install, coat bearings with Lucas Oil Marine grease before re-installing.
10. Install bearings and place hub on spindle in reverse order as listed above. Rotate the hub while applying approximately 50 ft. lbs. of torque to the spindle nut. This translates into a full hand pressure load with a 12" long wrench. This "seats" the bearings.
11. Loosen the spindle nut to remove the torque applied. **DO NOT ROTATE THE HUB.**
12. Tighten the spindle nut until snug, backing off only enough to line up the cotter pin with the hole in the spindle.
13. Bend the cotter pin into place
14. **LOAD HUB WITH LUCAS OIL MARINE GREASE USING THE INSTRUCTIONS FOR ADDING OR CHANGING GREASE**
15. Replace the Vortex grease cap. Turn in a clock-wise rotation until the O-ring on the cap in contact with the hub surface. Turn an additional 1/4 turn to seal the Vortex cap to the hub. (This is similar to installing an oil filter in an automobile)
16. Replace tire/wheel, torque lug nuts according to wheel manufacturers instructions.
17. Test hub for proper end play by grabbing the tire and pulling the tire from side to side. Readjust if necessary.

VERY IMPORTANT: RE-CHECK LUG NUTS AFTER 25 MILES OF USE.

TIE DOWN ENGINEERING

255 Villanova Drive SW, Atlanta, GA 30336

(404) 344-0000 • Fax (404) 349-0401

www.tiedown.com

© 2012 TIE DOWN ENGINEERING, ALL RIGHTS RESERVED

Instruction Manual #08135